

LCU-20 Series

Condensate Pump

Liberty Pumps®

A Family and Employee Owned Company

For removal of condensate from high efficiency furnaces, A/C equipment, ice machines, drinking fountains, beverage machines, dehumidifiers, and other applications requiring condensate removal

NEW
Updated
Design!



3
Year Warranty

Features

- High impact ABS tank
- Visual bubble level
- Wall mounts
- Four 1" intake holes
- 3/8" O.D. outlet
- Barbed discharge connection
- Removable check valve
- Stainless steel shaft
- 6' Power cord with ground
- Thermally protected
- Fully automatic
- Quiet operation
- Models with an "S" include built-in safety switch
- Models with a "T" include 20' of tubing
- Isolation pads pre-installed on tank



innovate. evolve.

LCU-20 Series

Applications

- High efficiency furnaces
- AC equipment
up to 682,000 BTU (200 kW)
- Ice machine
- Drinking fountains
- Dehumidifiers
- Other applications
requiring condensate removal



20' of discharge tubing included on models with a "T" suffix

Max Fluid Temperature

140°F (60°C) 50% Duty Cycle

Performance Curve

60 Hz

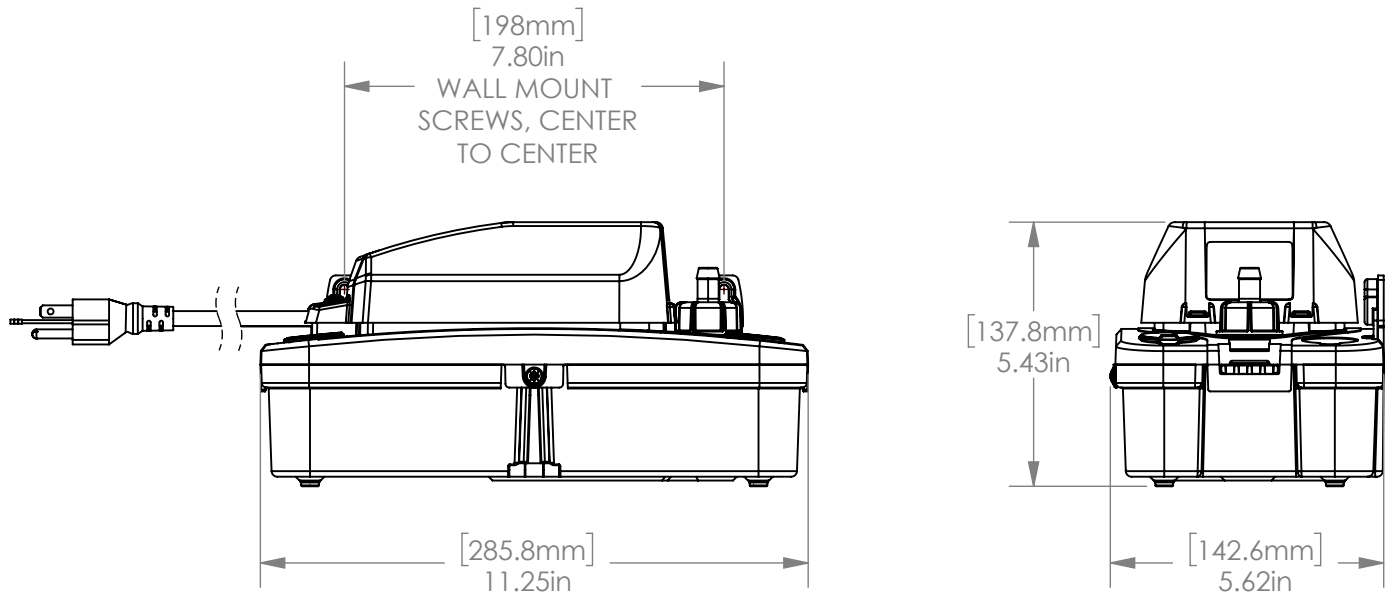
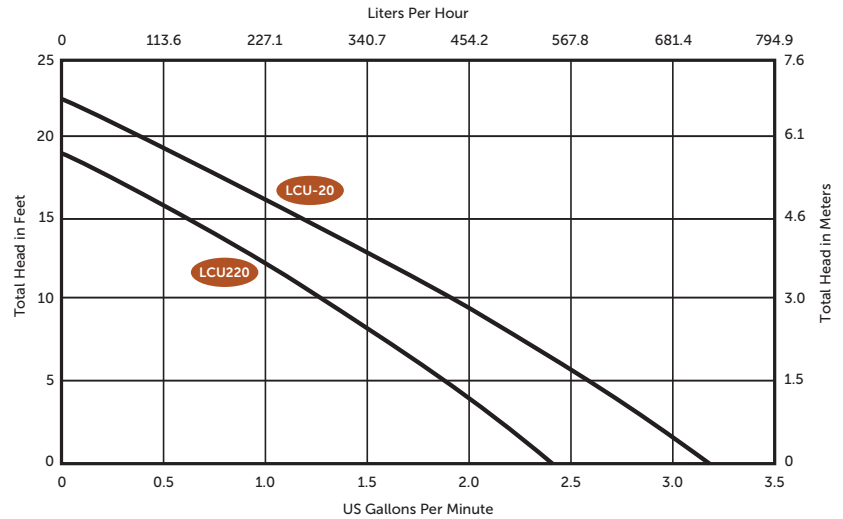

Models

MODEL	HP	VOLTS	AMPS	HEIGHT	LENGTH	WIDTH	WEIGHT IN LBS	CAPACITY	MAX HEAD	SAFETY SWITCH	20' TUBING
LCU-20S	1/9	115	1.6	5.5"	11-1/4"	5-5/8"	5	1.58 US Qt	22'	Yes	No
LCU-20ST	1/9	115	1.6	5.5"	11-1/4"	5-5/8"	6	1.58 US Qt	22'	Yes	Yes
LCU220S	1/10	230	0.7	5.5"	11-1/4"	5-5/8"	5	1.58 US Qt	19'	Yes	No
LCU220ST	1/10	230	0.7	5.5"	11-1/4"	5-5/8"	6	1.58 US Qt	19'	Yes	Yes